

THE USE OF A CORIOLIS FLOW METER FOR MEASURING MOLASSES PRODUCTION IN A SUGAR MILL.

P. W. Rein¹, D. J. Muzzell², and N. Dolan²

¹Audubon Sugar Institute, LSU AgCenter, St. Gabriel, LA,

²Raceland Raw Sugar Corp., Raceland, LA, USA

ABSTRACT

In order to obtain a reliable estimate of the loss of sugar in molasses and improve the accuracy of the estimated undetermined loss, a precise measure of molasses production is necessary. A Coriolis meter can measure mass flow rate with a quoted accuracy of better than 0.15 %. It also measures density simultaneously and can be installed directly in the molasses line. Experience with two different makes of Coriolis meters installed at Raceland mill is described. The accuracy of the meters is compared with routine molasses production figures from tank levels and from a newly installed molasses scale. Advantages and problems with the installations are discussed and the suitability for use on this duty is assessed.

INTRODUCTION

Good factory control relies on accurate data to calculate factory performance and efficiency. In order to obtain a reliable estimate of the undetermined sugar loss, it is necessary to obtain accurate measures of the other factory losses, i.e. loss in filter cake and loss in molasses. The latter usually represents the largest sugar loss in a sugar mill and a reliable measure is therefore most important.

In many mills, molasses quantity is obtained by measuring the molasses level in storage tanks on a regular basis. This is not accurate enough to obtain a measure of the mass loss of sucrose with sufficient accuracy. The error in the mass estimate affects the undetermined loss directly.

In other mills, batch scales are installed to measure molasses weights. This is the best method, but requires regular checking and maintenance. The use of a Coriolis meter provides a cheaper solution and has the required accuracy without the disadvantages of batch scales.

The undetermined loss in a well-run sugar mill is usually of the order of 1 to 2 % of the incoming sucrose. It can be much higher if control is not good. In order to estimate undetermined loss to within 0.1 %, it is necessary to measure the molasses loss with an accuracy of at least 1 %. Because of potential sampling and analysis errors, which also affect the estimate of molasses loss, a mass accuracy significantly better than 1% is desirable.

This paper covers the experience at Raceland sugar mill with the use of two different types of Coriolis meters over a period of three seasons. In the third season, a molasses scale was installed, which enabled a more accurate assessment of the suitability of these meters to be made.

OPTIONS FOR MOLASSES PRODUCTION MEASUREMENT

The methods used to measure molasses quantities in sugar mills include the following:

1. A batch scale system consists of a supply tank above a weigh hopper. The weigh hopper accepts batches of molasses from the supply tank and records the mass before discharging the molasses. The weigh hopper is tared before accepting each new batch. The weigh hopper is supported on three or four load cells to record the mass. Test weights are incorporated in the installation, so that the weighing system can be checked routinely and accurately. Quick acting, tight, shut-off butterfly valves have been adopted to speed up the operation of the scales. The scales will generally read to about 0.05 % accuracy for the mass of each tip, but the accuracy in operation is within 0.1 %. This is quite suitable for factory control purposes.

Some installation details need to be considered. Care must be taken to ensure that the molasses from the supply tank does not overflow directly into the receiving tank and by-pass the weigh hopper. The overflow should be routed back to the tank from which it was supplied and if necessary, a high level alarm should trip the supply pumps. The discharge from the butterfly valves should be visible, so that they can be readily checked for leaks. The structure supporting the weigh hopper should be rigid enough to ensure accurate mass determinations and preferably be free from vibration.

2. A magnetic flow meter is sometimes used to measure the input of raw juice into the factory. However it cannot be expected to give an accurate enough measurement. The installed accuracy is generally not better than 1 % and it measures volume and not mass flow. The flow measurement is also affected by juice density and by entrained air. Even the incorporation of an on-line density meter into the system does not lead to acceptable accuracy. This is definitely not suitable for molasses duty.
3. Production tank dipping is practiced in many mills. This is adequate if molasses production is reported on a volume basis. However, the factory balance is based on mass and not volume, and so, the mass has to be calculated using an assumed or a measured density. It is not easy to obtain an accurate measure, since the molasses is usually aerated to some extent, and in some cases, the occurrence of Maillard-type reactions leads to the generation of carbon dioxide, which does not escape and further affects the density and levels in the tank.
4. Tank monitoring by measuring the hydrostatic head in the tank overcomes the problems of varying density outlined above. This can be done using a flange-mounted pressure transmitter installed on the side at the bottom of the tank. However, the

Rein: The Use of a Coriolis Flow Meter for Measuring Molasses in a Sugar Mill

installed accuracy of this measure is not sufficiently good, and frequent calibration is necessary to be assured of accurate results.

5. A Coriolis meter has the required characteristics for accurate mass measurement. It can measure mass flows with an installed accuracy of 0.15 %. This type of meter can handle solids in the liquid, is insensitive to variations in temperature and pressure, has a high turndown ratio, and is virtually maintenance free. These meters are only marketed in smaller sizes, with the largest having an 80 or 100 mm pipe connection. This is fine for molasses but is unsuitable for raw juice flows above approximately 150 t/h. Some larger Coriolis meters are becoming available but at a cost. The 80 mm meters are expensive, of the order of \$10,000, but installation is cheap and easy and no lengths of straight piping are required before or after the meter. It is expected that prices will reduce in future as further improvements are made to these meters.

Coriolis meters have different designs with regard to the shape of the measuring system. The U-shaped tube was initially the most popular geometry and serves to illustrate the principle. Application of an excitation to the tube causes it to oscillate at its resonant frequency, while the flow enters at one end of the U and travels through to the other end. The oscillation is at right angles to the flow of liquid and is typically sinusoidal and thus characterized in terms of frequency, phase and amplitude. As material passes through the tubes, the flowing mass accelerates in the direction of oscillation. The tubing sees a force – the Coriolis force – that produces a twisting action, and the tube takes on the form of an S shape. Due to its inertia, the bending is out of phase with the oscillation, and the bending registers as a phase shift and is directly proportional to the mass passing through the tubes.

Most Coriolis meters have a double tube arrangement which produces a nominally balanced system and hence greater stability. Straight flow tubes are also used, but the bending is very small and the signal / noise ratio is reduced.

It appeared that a Coriolis meter would be well-suited to estimating the mass of molasses produced for the following reasons:

- They are very accurate flow meters, with an accuracy of around 0.1 %.
- They measure mass flow and do not require any estimates of molasses density.
- They are simple, robust, and are easy to install, without requirements of lengths of straight pipe before and after the meter.
- There are no flow restrictions, so suspended solids in the fluid are not a problem.
- They give a simultaneous output of fluid density.
- They are not sensitive to vibration.
- They have a good turndown ratio and are accurate at very low flow rates.

FLOW METER INSTALLATION

As part of the program to measure sucrose losses at Raceland mill for the 2002 season, an Endress + Hauser Coriolis meter was installed on the molasses line from the C centrifugals to the storage tanks. The specification for the meter was as follows:

- Fluid to be measured: Raw sugar mill molasses.
- Fluid temperature range: 40°C to 70°C
- Fluid density range: 1300 to 1400 kg/m³
- Fluid viscosity range: 60°C 1 – 2 Pa.s
50°C 2 – 4 Pa.s
40°C 4 – 8 Pa.s
- Flow rate range: 5 - 20 t/h
- Flow rate average: 16 t/h
- Transmitter outputs required: mass flow (instantaneous and totalizer), temperature and density.
- Required accuracy: 0.15 % of maximum mass flow rate or better.
- Suitable for interfacing to computer or other data acquisition equipment.
- Must be unaffected by entrained air and by changes in density and temperature.

A 3-inch diameter meter model 83F80 was installed.

For the following 2003 season, another 3-inch Coriolis meter manufactured by Foxboro, Model CFS20 Style B meter with CFT50 transmitter, was installed in series with the Endress + Hauser meter to facilitate comparisons. During the 2004 season, a molasses batch scale was installed at Raceland, so that the meters could be compared against an accurate mass flow measurement.

A sketch of the installation is shown in Figure 1. The molasses pump motors are switched on and off by the level switches on the pump supply tank. The molasses scale was supplied by Avery Berkel with a rated capacity of 25 t/h and a guaranteed accuracy of ± 0.1 %. It has a 300 kg weigh hopper operating at 1.4 tips / minute. The scale was not installed until 2004, the third year of this investigation.

RESULTS

During the 2002 season, it was clear that the Endress + Hauser Coriolis meter was giving a significantly higher measure of molasses quantity than the tank measurements suggested. It was found that a molasses line to a crystallizer back-blending system was installed after the meter and that some of the molasses to the crystallizers was returning to the supply tank and being weighed twice by the Coriolis meter. In addition, when the pumps stopped, the molasses was draining back to the supply tank. Both these problems were remedied during the following off-crop, but it was still suspected that the meter was over-reading. The molasses density measured by the meter was an instantaneous reading that was done at the end of the day. This was obviously unrepresentative, so a density

Rein: The Use of a Coriolis Flow Meter for Measuring Molasses in a Sugar Mill

was calculated in 2002 using the mass from the Endress + Hauser meter and the volume from the tank measurements. The density appeared initially to be too high, and at the end of the season after the meter was re-calibrated by the agents, the density was somewhat low at 1250 kg/m³. It was suspected that entrained air might be affecting the measurement, but this was reported to be unlikely by the suppliers.

For the 2003 season, a check valve was installed below the meter to stop molasses draining back into the supply tank. The Foxboro meter was installed in series with the Endress + Hauser meter. The Foxboro transmitter claims to have an innovative digital flow tube control to overcome flow interruption or stalling caused by two-phase flow; one system controls the meter's drive sequence to keep the system oscillation stable and another processes the measurement.

Both meters were affected by an unforeseen problem, namely the fact that the molasses pumps turn on and off regularly, as the molasses feed tank level changes. The meters were not always able to follow the step changes in flow that occurred, and were affected by air ingress if the level in the molasses feed tank dropped too low. The non-return valve below the meters ensured that the vertical line above the meters stayed full with molasses without draining.

Results for the two seasons 2003 and 2004 are shown in Table 1 together with the molasses scale data. The data for 2003 includes data only from day 31 when the Foxboro meter was installed and for 2004 includes only that part of the season from when the scale was installed (also day 31). The mill estimate data is obtained via the traditional method of tank dipping. The density for the Endress + Hauser is calculated from the tank volume and the Endress + Hauser meter mass.

	2003			2004		
	Mass Flow (t/day)	Density (kg/m ³)	Vol. Flow (m ³ /day)	Mass Flow (t/day)	Density (kg/m ³)	Vol. Flow (m ³ /day)
Mill Estimate	264.5	1286	206.7	215.7	1316	164.3
E + H	320.1	1554	-	242.3	1425	-
Foxboro	296.6	1436	206.6	233.3	1421	164.2
Scales	-	-	-	225.7	-	-

Table 1. Comparison of Coriolis meter measurements of molasses production with Raceland mill data.

The data obtained in 2003 showed clearly that the molasses quantity recorded by the mill was too low. The magnitude of the difference suggests that the mill estimate was too low by about 10 to 15 %. The underestimation was confirmed once the scales were installed, but showed only a 5 % under-estimate by comparison with the scales.

An interesting feature of the data in Table 1 is the fact that the Foxboro meter volumetric estimate and the mill tank dipping volume agreed very closely. The magnitude of the difference in densities was responsible for the discrepancy in the mass figures. The molasses sample for density measurement in the laboratory was taken from the sample point directly below the meters. The density was determined six times per day by weighing exactly 2 liters of molasses and calculating the density from the mass and volume. This method was checked numerous times when this discrepancy was noticed, and the difference in densities between the mill and the Foxboro meter could not be explained. However, the mill estimate appears to be too low by comparison with other published data and may have become slightly aerated in the process of sampling and analysis.

Figures 2 and 3 show the daily average molasses quantities, for the two meters compared to the factory data from tank dipping in 2003 and the molasses scales data in 2004. Figure 2 shows the consistent discrepancy between the meters and the mill figure obtained by tank dipping. It also shows that the reading of the Endress + Hauser meter was consistently above that of the Foxboro meter.

The 2004 data in Figure 3 show that both meters recorded higher molasses quantities than the molasses scale. On average, the Foxboro meter gave readings that were 3 % higher and the Endress + Hauser meter 9 % higher. Opportunity was given to both suppliers to adjust their meters as necessary towards the end of the season in an attempt to eliminate the discrepancy. This accounts for some of the missing data towards the end of the season. There was some indication that the agreement between the scales and the Endress + Hauser meter improved in the last few days of the season. If this is the case, it gives the lie to their claim that their Coriolis meter is a “fit and forget” solution.

It is clear from comparing Figures 2 and 3 that the Coriolis meters follow the batch scale data much closer than they do the molasses tank dipping data shown in Figure 2. This shows the unreliability of the dipping method and suggests that the Coriolis meters respond more closely to real changes in flow rate.

There is no guarantee that the molasses scale installation gives data that is entirely accurate. The installation represented in Figure 1 shows the valves on the pipes to the two molasses storage tanks, which were used to measure the molasses volume before the scales were installed. If either one of the valves was not leak-tight, molasses would bypass the scale and enter the storage tank directly. In this case, the scale could be expected to under-read. While this is not considered likely with the knowledge of the valves condition, it cannot be ruled out entirely.

DYNAMIC BEHAVIOR OF CORIOLIS METERS

The way in which the two meters behaved when the molasses pumps started and stopped proved to be quite interesting. The molasses pump generally ran for a period of

Rein: The Use of a Coriolis Flow Meter for Measuring Molasses in a Sugar Mill

between 2 and 8 minutes before turning off. If one pump could not handle the flow, a second pump would turn on automatically; this however did not happen very often.

There were two other factors that made this a difficult flow measurement duty. It was observed at times that the low level switch in the molasses tank at the centrifugals was set too low, so that the pump sucked air for a short period before the pump switched off. Most Coriolis meters are reported to be able to handle up to about 15 % air by volume without trouble, and the Foxboro meter specifically has been developed to handle entrained air. However, the sudden change in the degree of aeration would challenge any meter. The second problem was the fact that water was added to the molasses tank to dilute the molasses slightly. This water did not mix well in the tank, so it often happened that the last bit of liquid through the meters before the pump stopped was a dilute solution of molasses in water. This represented a sudden density change.

Recordings of some of the meter outputs are shown in Figures 4 to 6. In these figures, the time interval on the x-axis between verticals is 2 minutes and the vertical scale represents the flow in t/h (maximum 50 t/h) for the Foxboro meter (red) and the Endress + Hauser instrument (blue). The average molasses flow with one pump in operation was usually just less than 20 t/h. The green trace is the density signal from the Foxboro instrument; the full-scale reading is 2000 kg/m³, indicating a molasses density around 1400 kg/m³.

The worst situation is shown in Figure 4. The density signal indicates a feed of unsteady density, affected by water and/or air entrainment. When the pump stops, the flow indicated by the Endress + Hauser instrument does not return to zero. The density drops after the pump stops and increases again to expected density values at startup. Figure 4 shows the density dropping on pump shut-down to a value close to 1000 kg/m³, indicating water in the meter.

Figure 5 shows the situation where the lower level switch had been adjusted to stop the pump at a level above the suction line from the tank. The density trace is now far more steady, although it still does show a small spike when the pump started and stopped. The faster response of the Foxboro meter shows a corresponding spike in mass flow. Note in Figure 5 and 6 the volumetric flows are shown as well as the mass flows (light green and orange traces).

Figure 6 displays a feature often observed, namely a drop in density when the pump stops. A drop of about 5 % was noticed, leading to speculation that the static pressure at that point reduces in the absence of a frictional pressure drop, such that any entrained air in the molasses expands, thus reducing the density. This could explain part of the discrepancy between the recorded density and the density measured in the laboratory. However, this effect was not always seen as for instance in Figure 5, which does not show the same density drop when the pump stops.

In general, it could be seen that the Foxboro instrument has a faster response, which is important in this type of application. Even in the presence of entrained air and

water, the Foxboro instrument output always returned to zero when the pump was not running, albeit with some severe fluctuation. The Endress + Hauser instrument was not always able to do this.

CONCLUSIONS

The Coriolis meters have been tried in a very testing application, having to handle frequent flow stop / starts, thus representative of a batching application rather than a continuous process. The interesting behavior of the two meters tested in this application is not really relevant to continuous operation. The effect of aeration of molasses on molasses density does indicate clearly that volumetric measures of molasses flow measurement will never be accurate.

By comparison with a batch molasses scale, the Foxboro and Endress + Hauser meters are shown to over-read by 3 and 9 % on average. It is likely that this is a consequence of the mode of operation.

There is enough evidence to suggest that the Coriolis meter could achieve its stated accuracy in an application where a continuous molasses flow is measured, and could be a good cost-effective option for molasses production measurement. This has not been proven here. The batch scale has the advantage that it can be used either for a continuous or discontinuous flow system, but costs more than twice the price. The installed cost difference is likely to be even higher.

The Coriolis meter is the only suitable alternative to a batch scale for an acceptably accurate flow measurement. It has a number of advantages listed in this paper. Further work will be done in the following season, with the Endress + Hauser meter installed at another mill that has a steady molasses flow, and continuing evaluation of the accuracy of the Foxboro meter on the more testing application at Raceland. This should give a good indication of whether the on/off operation is entirely the cause of differences in recorded molasses quantities.

ACKNOWLEDGEMENTS

This work was partially sponsored by The American Sugar Cane League. Our thanks are due to them and the staff at Raceland who assisted in this work. The generous support of Foxboro is also acknowledged.

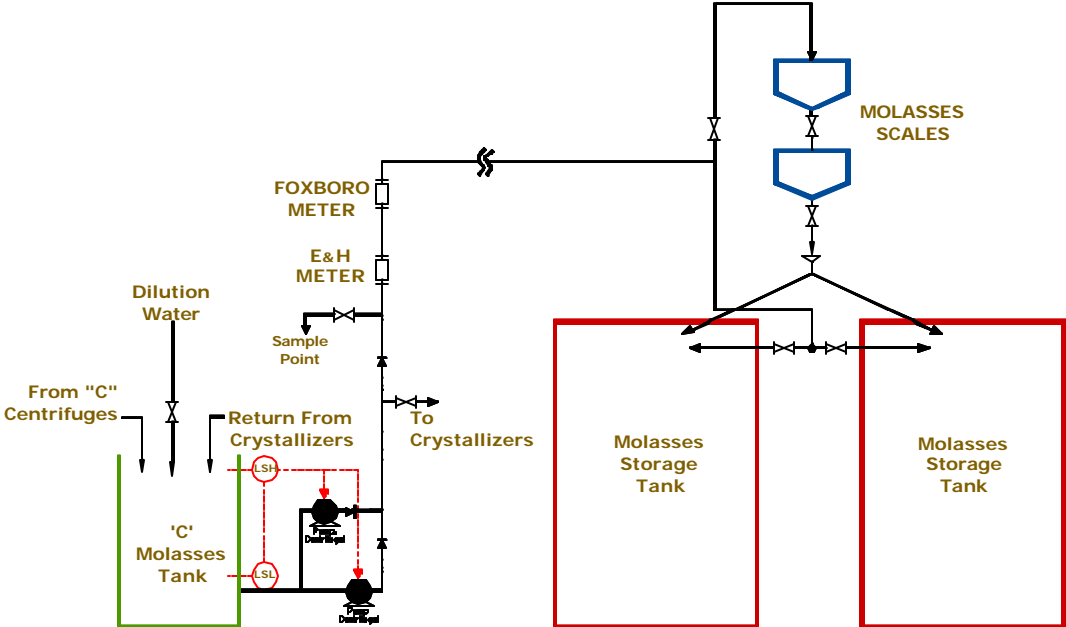

Figure 1. Molasses flow system at Raceland.

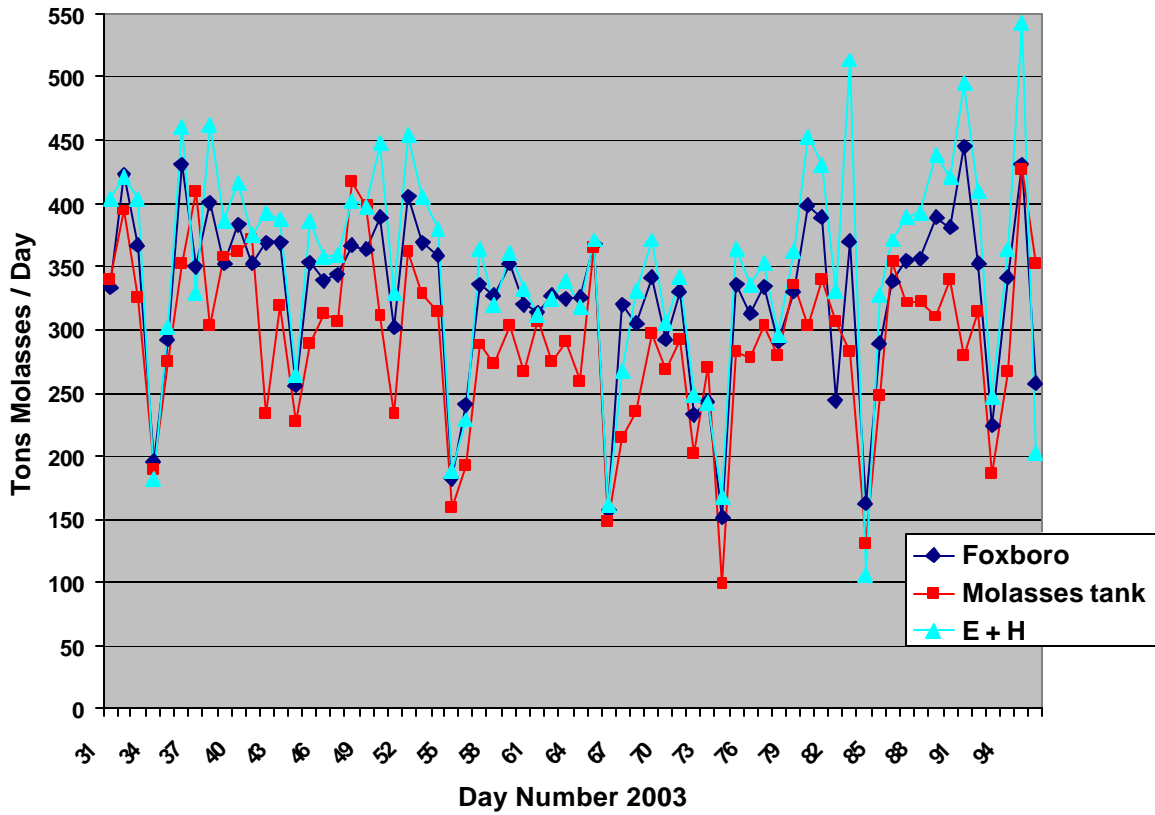

Figure 2. Comparison of two Coriolis meters with mill measurement of molasses quantity, 2003 season at Raceland.

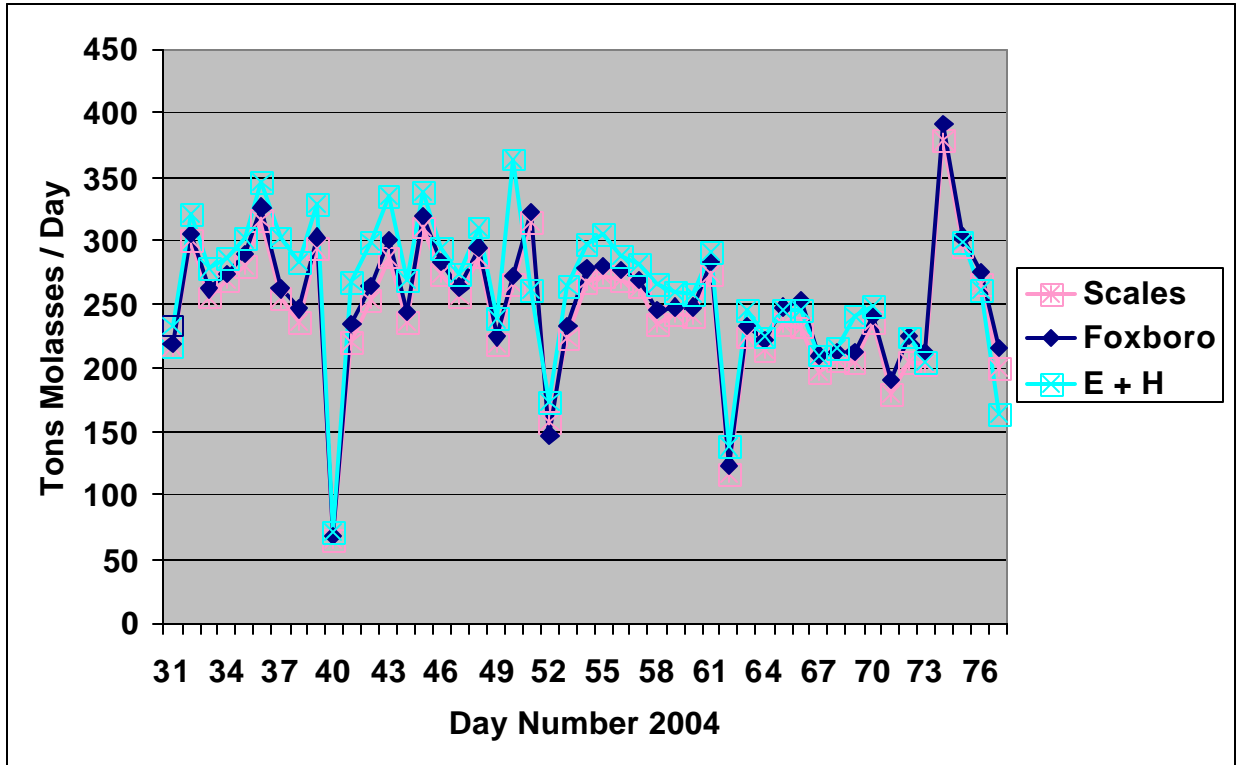

Figure 3. Comparison of measurement of molasses quantity by two Coriolis meters compared with batch molasses scales, 2004 season.

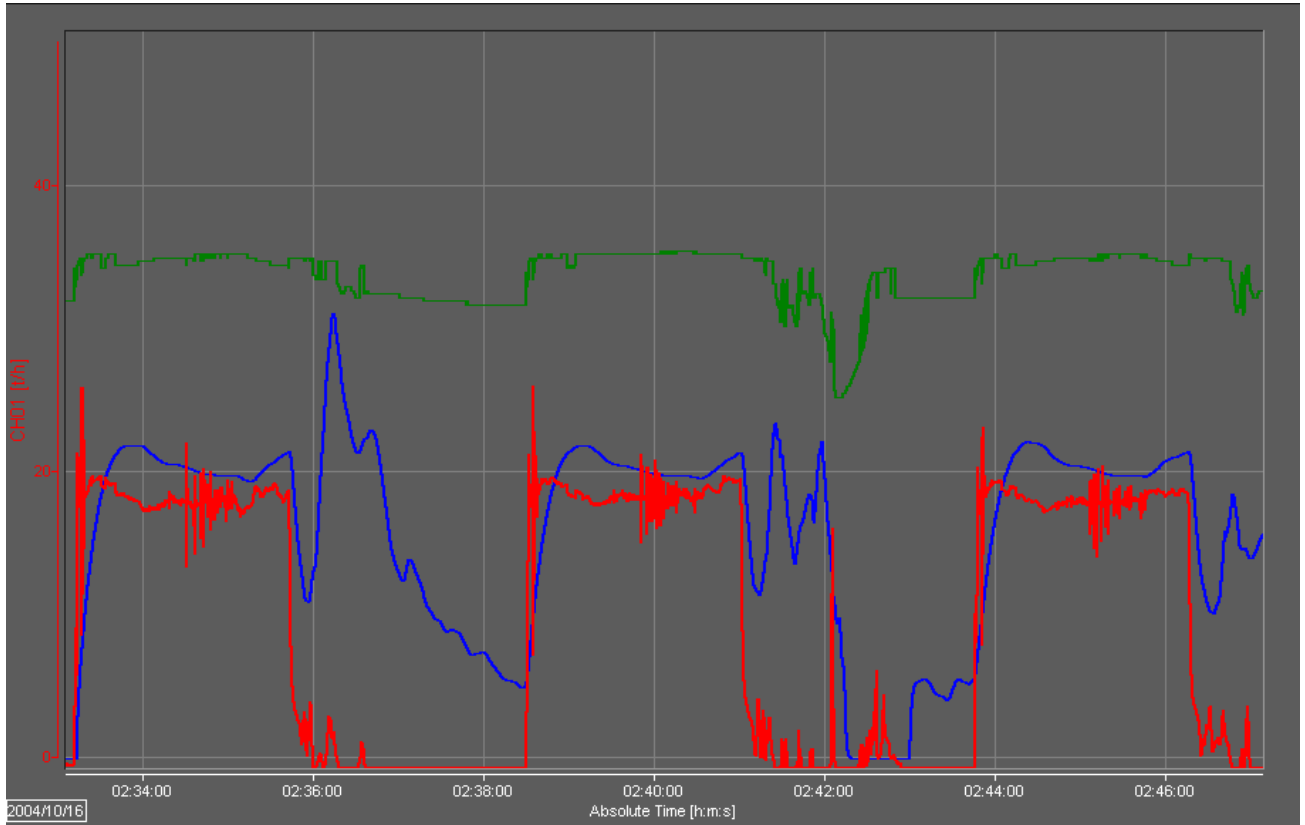

Figure 4. Coriolis meter recordings showing mass flow (red Foxboro, blue Endress + Hauser) and density (green) over a period of 14 minutes.

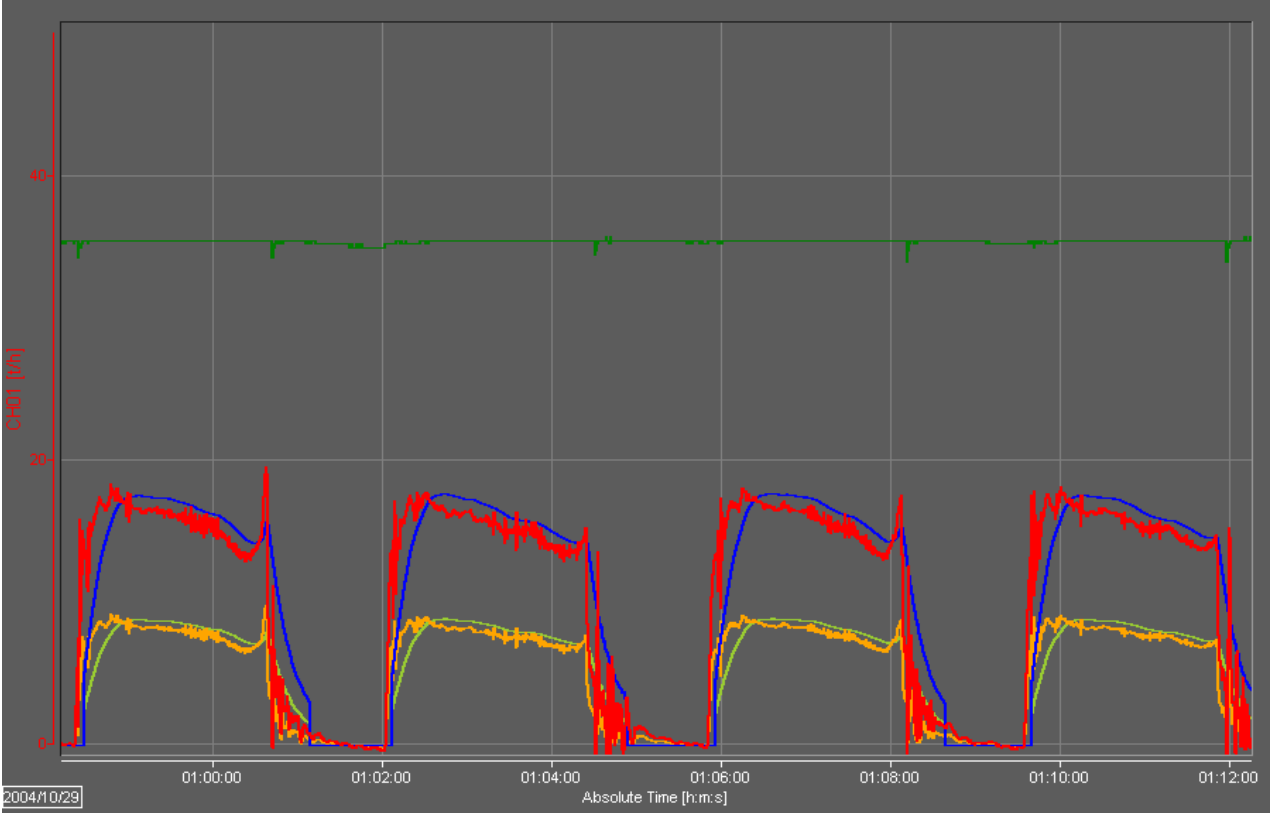

Figure 5. Coriolis meter recordings showing mass flow (red Foxboro, blue Endress + Hauser) and volumetric flow (orange and light green respectively), under conditions of steady density (green trace).

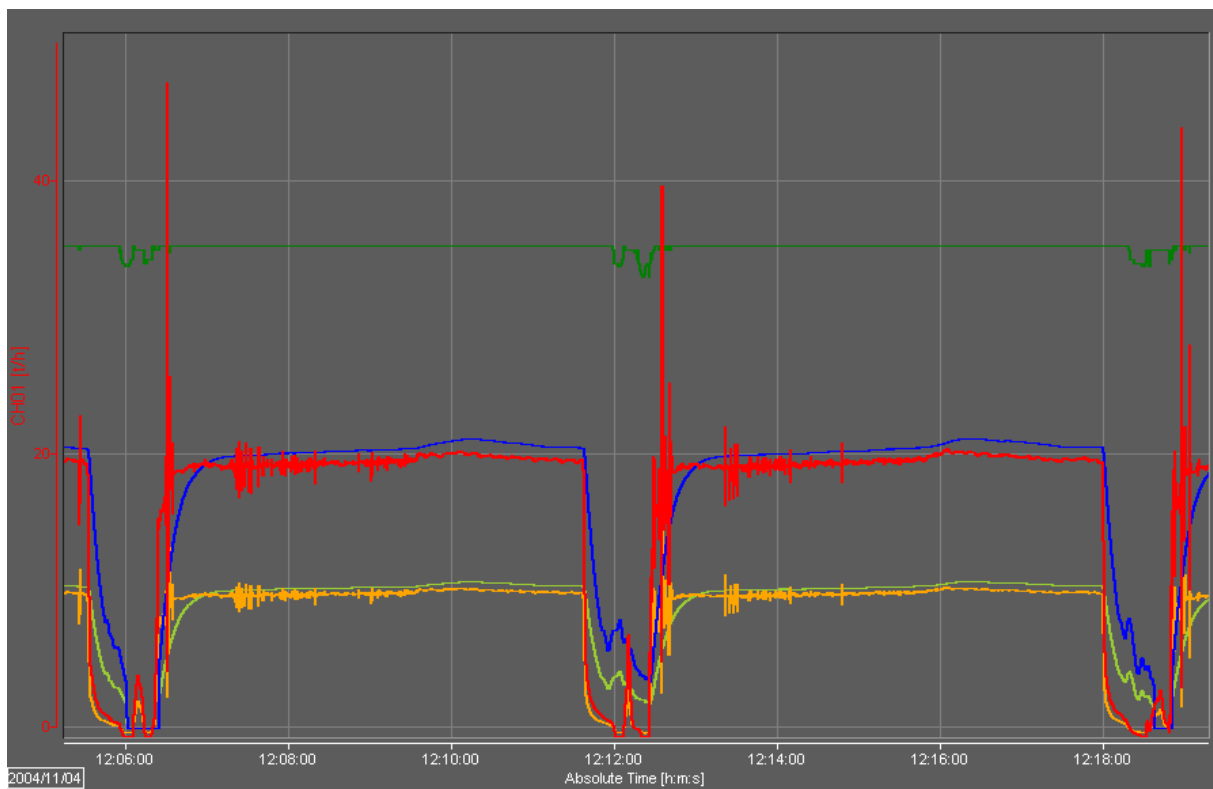

Figure 6. Further example of Coriolis meter recordings showing mass flow (red Foxboro, blue Endress + Hauser) and volumetric flow (orange and light green respectively).